

Name: _____ Date: _____
 Track: _____ Event: _____

Track Conditions Indoor Outdoor Tight Open Smooth Rough Hard Packed Loose/Loamy Blue Groove Dry Wet Dusty Low Bite Med Bite High Bite Other _____

Front Suspension

Toe: _____
 Ride Height: _____
 Camber: _____
 Caster: _____
 Sway Bar: _____
 Oil: _____
 Piston: _____
 Spring: _____
 Limiters: _____
 Spindle Height: _____
 Axle Spacer: _____
 Steering Type: _____
 Bump Steer: _____
 Camber Link: _____
 Shock Location: _____
 VLA: _____
 Front Wing: _____

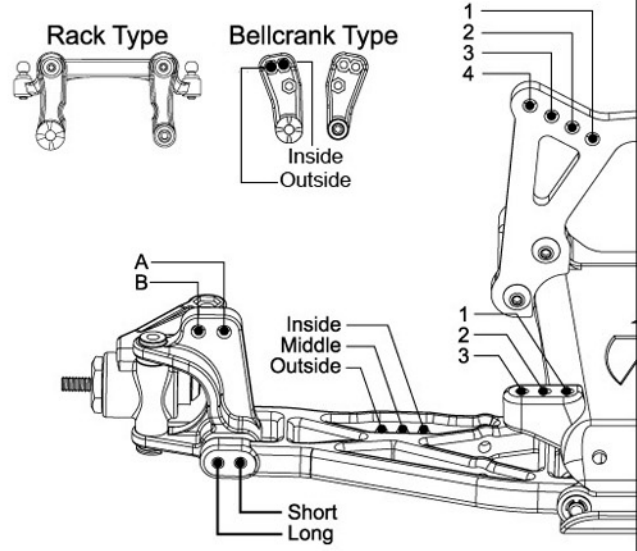

Notes: _____

Rear Suspension

Toe: _____
 Pivot Support: _____
 Ride Height: _____
 Camber: _____
 Rear Hub Spacing: _____
 Drive Shafts/Outdrives: _____
 Sway Bar: _____
 Oil: _____
 Piston: _____
 Spring: _____
 Limiters: _____
 Camber Link: _____
 Shock Location: _____
 VLA: _____
 Wing Position/Mount: _____
 Body & Wing Type: _____
 Battery Position: _____

- LHD
- RHD

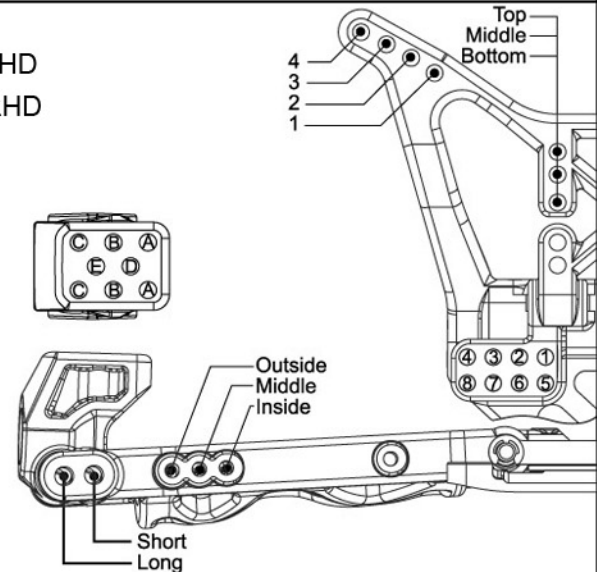

Notes: _____

Weight Placement
 (Mark with "X")

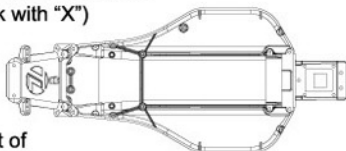

Weight of each piece _____ oz.

Tires:	Type	Compound	Insert	Additive	Motor:
Front:	_____	_____	_____	_____	_____
Rear:	_____	_____	_____	_____	_____
Notes:	_____				Pinon: _____
	_____				ESC: _____
	_____				Reverse rotor <input type="checkbox"/>